

Negative supply for measurements below 0°C and extends range

Do not implement this section.

Note: We no longer recommend using the MAX1044 due to the noise it creates. If you need to measure below 0°C you will need to provide a clean negative supply.

NOTE: Follow layout on data sheet

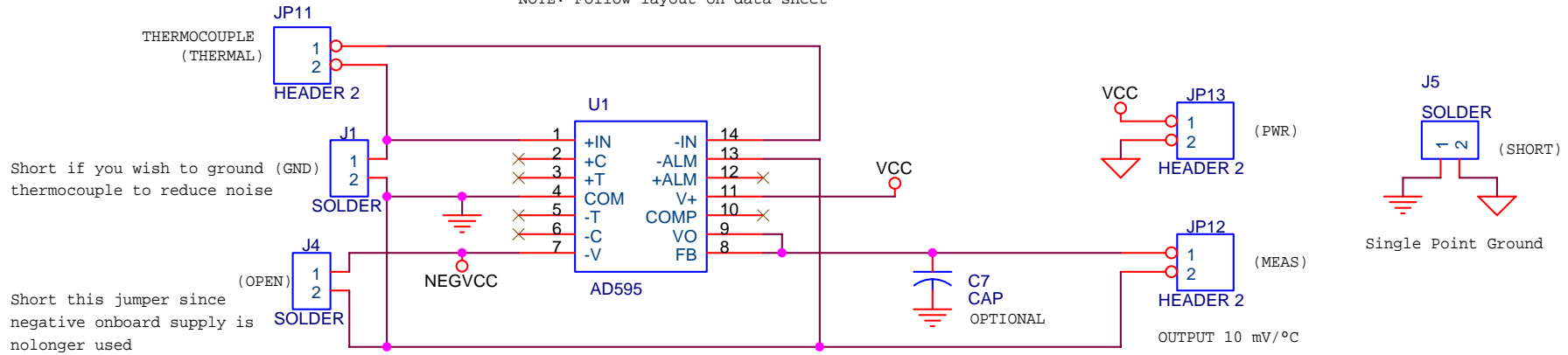

Short if you wish to ground (GND) thermocouple to reduce noise

Short this jumper since negative onboard supply is no longer used

Type J (AD594) or
Type K (AD595) Thermocouples
Built-In Ice Point Compensation

Embedded Acquisition Systems
2571 Cobden Dr.
Sterling Heights, MI 48310
WEB <http://www.embeddedtronics.com>
EMAIL sales@embeddedtronics.com
Copyright 2004

Title		
Thermocouple Interface		
Size	Document Number	Rev
A	Thermocouple plus cold junction	B
Date:	Wednesday, March 24, 2004	Sheet 1 of 1